

## **INSTRUCTION MANUAL PIPE LASER**

---

### **TP-L4 SERIES**

**TP-L4G**

**TP-L4A**

**TP-L4B**

**TP-L4BG**



## FOREWORD

Thank you for purchasing the TOPCON Pipe Laser TP-L4 series.

---

The TP-L4 instrument has unique features based on the model. These include:

- High-visibility green laser beam on models TP-L4G and TP-L4BG. The green laser is over four times more visible to the human eye, making it easier to accurately use the laser over longer distances—inside or outside the pipe.
  - Automatic beam alignment on models TP-L4G and TP-L4A. The laser beam will automatically locate and lock onto the center of the pipe target placed in its path.
  - High-resolution laser spot on all models, making it easy to accurately locate the center of the beam.
- 

This instruction manual describes procedures for safe use, operation and maintenance of TP-L4.

For the best performance of the instrument, please carefully read these instructions and keep them in a convenient location for your future reference.

---

## General Handling Precautions

• Before starting work or operation, be sure to check that the instrument is functioning correctly with normal performance.

• When setting up the instrument, position it so the bubble in the digital level vial on the display is in the center position (See page 1-3).

• When you remove the instrument from the carrying case, be sure to open the cover of the case after laying the case down, right side up.

• When using an external power supply, it should be rated between 11 and 14 volts DC.

• Be sure to check the power level of the on-board battery pack before using the instrument.

• When you insert the dry battery in the instrument, be sure to insert in the shown direction. The insertion in reverse direction causes fault.

• Remove the dry cells from the instrument when you will not use it for more than one month.



• Physical reflection and refraction may occur under hot weather conditions or in a small pipe diameter due to its temperature or moisture conditions. To minimize the effect of these conditions please take the following precautions.

- 1) Place the pipe hot side (heated by sunlight etc.) down.
- 2) Do not apply an excessive amount of "pipe adhesive" to the pipe joints.
- 3) Immediately back fill the trench as pipe work is finished.
- 4) Set the instrument on top of the pipeline.
- 5) Use a blower or fan to move air through the pipe.

## Notice for Safe Use

In order to encourage the safe use of products and prevent any danger to the operator and others or damage to properties, important warnings are put on the products and inserted in the instruction manuals.

We suggest that everyone understand the meaning of the following notices and icons before reading the "Safety Cautions" and text.

Display	Meaning
 <b>WARNING</b>	<b>•Ignoring or disregard of this notice may lead to the danger of death or serious injury.</b>
 <b>CAUTION</b>	<b>•Ignoring or disregard of this notice may lead to personal injury or physical damage.</b>
<ul style="list-style-type: none"> <li>● Injury refers to hurt, burn, electric shock, etc.</li> <li>● Physical damage refers to extensive damage to buildings or equipments and furniture.</li> </ul>	

## Safety Cautions



### WARNING

#### Prevention item

- **There is a risk of fire, electric shock or physical harm if you attempt to disassemble or repair the instrument yourself.**

This is only to be carried out by TOPCON or an authorized dealer, only!

- **Risk of fire or electric shock.**

Do not use damaged power cable, plug and socket.

- **May ignite explosively.**

Never use an instrument near flammable gas, liquid matter, and do not use in a coal mine.

- **Cause eye injury or blindness.**

Do not stare into beam or view directly with optical instruments.

- **Cause eye injury or blindness.**

Do not stare into beam.

- **Battery can cause explosion or injury.**

Do not dispose in fire or heat.

- **Risk of fire or electric shock.**

Do not use a wet battery or charger.

- **Do not cover the charger while it is charging.**

Risk of fire or electric shock.

- **Laser beam can cause injury to eye or skin.**

Avoid exposure to beam.

- **Battery can cause outbreak of fire.**

Do not use any other type of charger than the one specified.

- **Risk of fire or electric shock.**

Do not use any other power cable other than the one specified.

- **Risk of fire.**

Do not use any power voltage except the one given on manufacturers instructions.

- **The short circuit of a battery can cause a fire.**

Do not short circuit battery when storing it.

**CAUTION****Prevention item**

Use of controls or adjustment or performance of procedures other than those specified herein may result in hazardous radiation exposure.

Do not connect or disconnect equipment with wet hands, you are at risk of electric shocks if you do!

Do not place yourself or a reflecting object in the path of the laser beam. If using the laser outside the pipe, avoid positioning it anywhere near eye level to avoid any possibility of it striking someone in the eye. If this should happen, visibility could be temporarily impaired, causing disorientation and possible accidental injury.

Do not allow skin or clothing to come into contact with acid from the batteries, if this does occur then wash off with copious amounts of water and seek medical advice.

Do not stand or sit on the carrying cases.  
It could overturn, causing injury.

Do not use a damaged instrument case.  
It could accidentally open causing damage to the instrument or injury to people.

Do not place instrument on unstable platform, surface or tripod.  
If using tripod, make sure instrument is securely attached.

## User

Wear the required protectors (safety shoes, helmet, etc.) when operating.

## Exceptions from Responsibility

- 1) The user of this product is expected to follow all operating instructions and make periodic checks of the product's performance.
- 2) The manufacturer, or its representatives, assumes no responsibility for results of a faulty or intentional usage or misuse including any direct, indirect, consequential damage, and loss of profits.
- 3) The manufacturer, or its representatives, assumes no responsibility for consequential damage, and loss of profits by any disaster, (an earthquake, storms, floods etc.), a fire, accident, or an act of a third party and/or a usage any other usual conditions.
- 4) The manufacturer, or its representatives, assumes no responsibility for any damage, and loss of profits due to a change of data, loss of data, an interruption of business etc., caused by using the product or an unusable product.
- 5) The manufacturer, or its representatives, assumes no responsibility for any damage, and loss of profits caused by usage except for explained in the user manual.
- 6) The manufacturer, or its representatives, assumes no responsibility for damage caused by wrong movement, or action due to connecting with other products.

## Laser Safety

### Safety Information

This product uses a invisible laser beam, and is manufactured and sold in accordance with "Performance Standards for Light-Emitting Products" (FDA/BRH 21 CFR 1040) or "Radiation Safety of Laser Products, Equipment Classification, Requirements and User's Guide" (IEC Publication 825) provided on the safety standards for laser products.

As per the said standard, this product is classified as a "Class 3A (IIIA) Laser Product". This is a simple product to operate and does not require training from a laser safety officer. In case of any failure, do not disassemble the instrument. Contact TOPCON or your TOPCON dealer.

### Labels

The labels on your unit may be slightly different from the samples shown due to specific local requirements.

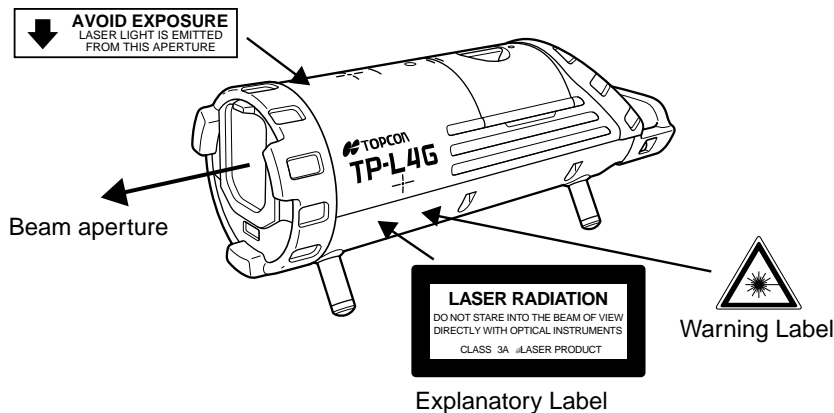



# Contents

FOREWORD	1
General Handling Precautions	2
Notice for Safe Use	3
Safety Cautions	4
User	6
Exceptions from Responsibility	6
Laser Safety	6
Contents	7
Standard Package Components	8
1 NOMENCLATURE AND FUNCTIONS	1-1
1.1 Nomenclature	1-1
2 PREPARING FOR USE	2-1
2.1 Power Source	2-1
2.1.1 Using On-board Battery of BT-53Q, DB-53	2-1
2.1.2 Using 12 volt DC battery	2-1
2.2 Setting TP-L4 (all models)	2-2
2.3 Grade setting procedure	2-3
2.3.1 Direct entry of grade value	2-3
2.3.2 Set grade value by moving laser	2-3
2.4 Setting Laser Line	2-4
2.4.1 Automatic Centering	2-4
2.4.2 Automatic alignment with the target (TP-L4G and TP-L4A only)	2-5
2.5 Changing the laser beam mode	2-6
3 STANDARD ACCESSORIES	3-1
3.1 Self Centering Feet and Single Point Foot	3-1
3.1.1 Single point foot	3-1
3.2 Remote Controller, RC-200	3-1
3.3 Safety Lock System	3-3
3.4 Replacing battery for Remote Control, RC-200	3-3
3.5 Target	3-3
4 OPERATION EXAMPLE	4-1
4.1 Pipe Laying	4-1
4.1.1 Setting TP-L4G/A/B/BG	4-1
4.1.2 Setting grade	4-2
4.1.3 Setting line	4-3
4.1.4 Setting Excavation, Base Material and Pipe Elevation (Fig.5)	4-5
4.1.5 In-the-Pipe Set up	4-6
4.1.6 Grade Checking	4-7
5 POWER SOURCE AND CHARGING	5-1
5.1 Dry battery (Alkaline) pack DB-53 (Optional Accessories)	5-1
5.1.1 Removing	5-1
5.1.2 Replacing	5-1
5.2 Rechargeable battery pack BT-53Q	5-1
5.2.1 Removing and Installing	5-1
5.2.2 Charging	5-1
5.2.3 Charging while operating from DC 12V external battery	5-2
6 CHANGING OPERATING PARAMETERS	6-1
6.1 Operating Parameters	6-1
6.2 How To Change Operating Parameters	6-2
6.3 How to Input (Change) Security Code	6-3
6.4 How to Change Company Name	6-5
7 CHECKING AND ADJUSTING CALIBRATION	7-1
7.1 Procedure To Check and Adjust Laser Calibration	7-1
7.1.1 Checking Calibration	7-1
7.1.2 Adjusting Calibration	7-1
8 ERROR DISPLAYS	8-1
9 TROUBLESHOOTING	9-1
10 OPTIONAL ACCESSORIES	10-1
11 SPECIFICATIONS	11-1

## Standard Package Components

<b>Composition</b>	
Target.....	1set
AC/DC converter .....	1pc.
Battery adapter BA-2.....	1set
Battery BT-53Q.....	1pc.
Carrying case .....	1pc.
Self-centering Feet	
Ø 150mm .....	1set
Ø 200mm .....	1set
Ø 250mm .....	1set
Ø 300mm .....	1set
Single point foot .....	1pc.
Remote controller RC-200 .....	1pc.
Instruction manual .....	1vol.
Warranty card .....	1vol.

Make sure that all of the above items are with the instrument when purchased.  
 (If you purchased other than a standard package, please confirm the contents  
 with your local Topcon dealer.)

FOREWORD	1
General Handling Precautions	2
Notice for Safe Use	3
Safety Cautions	4
User	6
Exceptions from Responsibility	6
Laser Safety	6
Contents	7
Standard Package Components	8
1 NOMENCLATURE AND FUNCTIONS	1-1
1.1 Nomenclature	1-1
2 PREPARING FOR USE	2-1
2.1 Power Source	2-1
2.1.1 Using On-board Battery of BT-53Q, DB-53	2-1
2.1.2 Using 12 volt DC battery	2-1
2.2 Setting TP-L4 (all models)	2-2
2.3 Grade setting procedure	2-3
2.3.1 Direct entry of grade value	2-3
2.3.2 Set grade value by moving laser	2-3
2.4 Setting Laser Line	2-4
2.4.1 Automatic Centering	2-4
2.4.2 Automatic alignment with the target (TP-L4G and TP-L4A only)	2-5
2.5 Changing the laser beam mode	2-6
3 STANDARD ACCESSORIES	3-1
3.1 Self Centering Feet and Single Point Foot	3-1
3.1.1 Single point foot	3-1
3.2 Remote Controller, RC-200	3-1
3.3 Safety Lock System	3-3
3.4 Replacing battery for Remote Control, RC-200	3-3
3.5 Target	3-3
4 OPERATION EXAMPLE	4-1
4.1 Pipe Laying	4-1
4.1.1 Setting TP-L4G/A/B/BG	4-1
4.1.2 Setting grade	4-2
4.1.3 Setting line	4-3
4.1.4 Setting Excavation, Base Material and Pipe Elevation (Fig.5)	4-5
4.1.5 In-the-Pipe Set up	4-6
4.1.6 Grade Checking	4-7
5 POWER SOURCE AND CHARGING	5-1
5.1 Dry battery (Alkaline) pack DB-53 (Optional Accessories)	5-1
5.1.1 Removing	5-1
5.1.2 Replacing	5-1
5.2 Rechargeable battery pack BT-53Q	5-1
5.2.1 Removing and Installing	5-1
5.2.2 Charging	5-1
5.2.3 Charging while operating from DC 12V external battery	5-2
6 CHANGING OPERATING PARAMETERS	6-1
6.1 Operating Parameters	6-1
6.2 How To Change Operating Parameters	6-2
6.3 How to Input (Change) Security Code	6-3
6.4 How to Change Company Name	6-5
7 CHECKING AND ADJUSTING CALIBRATION	7-1
7.1 Procedure To Check and Adjust Laser Calibration	7-1
7.1.1 Checking Calibration	7-1
7.1.2 Adjusting Calibration	7-1
8 ERROR DISPLAYS	8-1
9 TROUBLESHOOTING	9-1
10 OPTIONAL ACCESSORIES	10-1
11 SPECIFICATIONS	11-1

# 1 NOMENCLATURE AND FUNCTIONS

## 1.1 Nomenclature

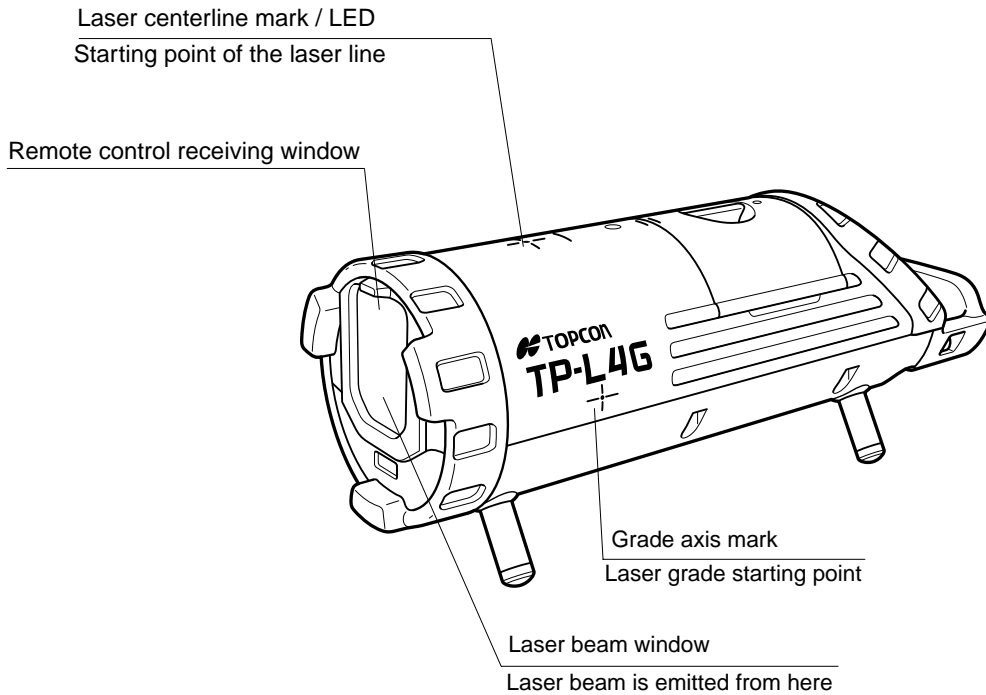
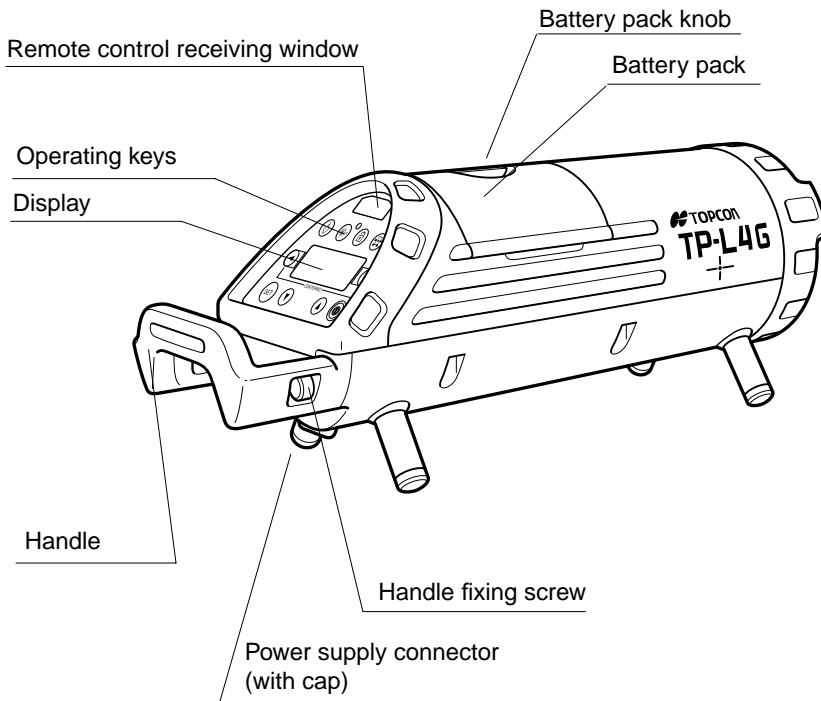

## Operating Panel

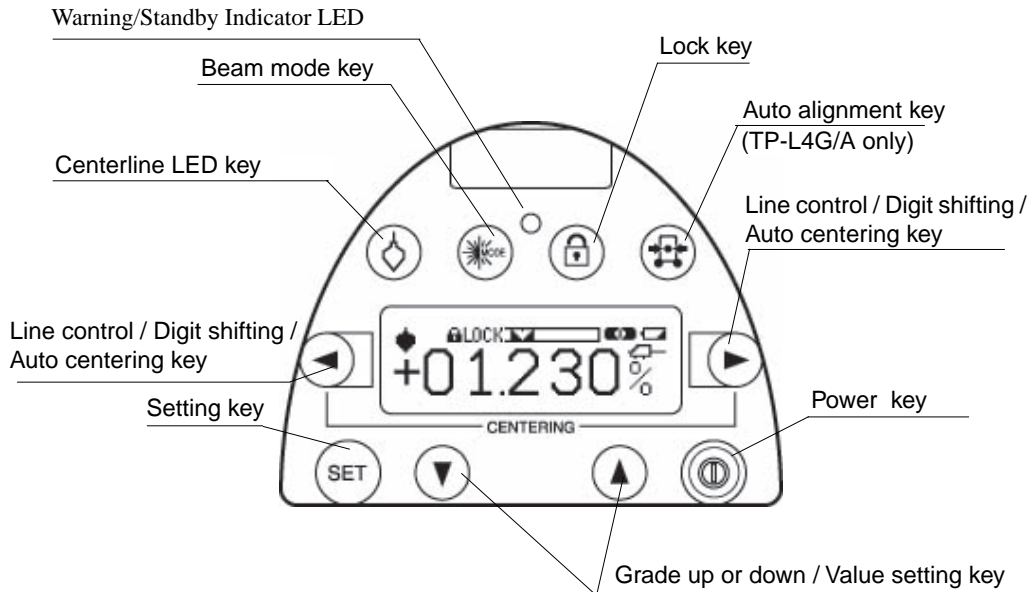

\*The illumination of the display will be ON for 30 seconds whenever anyone key is pressed.

Key	Name	Functions
	Centerline LED key	Turn the centerline LED ON or OFF by pressing. (Auto shut off after 30 minutes.)
	Beam mode key	The mode of laser beam is switched alternately. (Standard power, high power)
	Lock key	This key prevents input from grade control keys. Pressing again releases this function.
	Auto alignment key	The laser beam is aligned to the center of the target automatically.
	Line control / Digit shifting / Auto centering key	Press to move the laser beam to the right or to the left. Active indicating digit shifts to the right or the left. By pressing both keys at the same time, the laser beam returns to the center automatically.
	Grade up or down / Value setting key	Press to move the laser beam up or down. Positive and negative values are indicated in the display for grade setting. By pressing both keys at the same time, returns grade to 00.000%.
	Setting key	Press to enter grade shown on display.
	Power key	Turn the instrument ON or OFF.
	Warning/Standby Indicator LED	Flashes to indicate warning or standby mode.

## Indicators

Digital level vial, rotate instrument until centered

Laser line indicator

Indicates the direction of the laser line.

Centerline LED indication

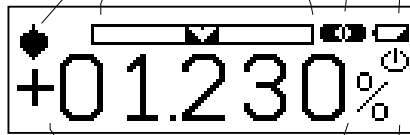

Grade indication

Percent or Permilli symbol

Lock indicator

Indicates when the instrument is locked.

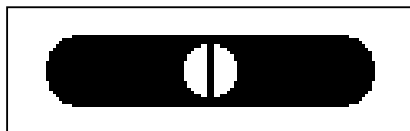
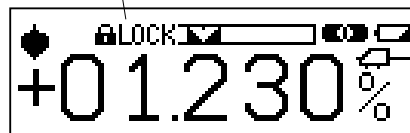

### Level vial display indicates instrument rotation status

When the instrument is titled sideways, the small level vial indicator on the display enlarges to fill the entire display to aid the user in accurate instrument setup. (see section 6, Setting Operating Modes for more information)

### Battery warning indication

Remaining battery capacity is shown in 3 steps.



Okay to operate.

Operating time is limited. Recharging or alternate power will be required soon.

Charging while using 12 volt DC external battery.

Blinking

### Self leveling indication (Flashing)

Flashes when the instrument is auto leveled. After self leveling is finished, the display changes laser mode.

### Laser mode indication



ON mode



Blinking mode



High power mode (TP-L4G/BG only)

## Warning indications



### Battery warning indication

Operating is impossible, and the laser beam is not emitted. Replace or recharge the battery.



### Level warning indication

The instrument tilted beyond the auto-leveling range to the back or front.

Reposition the instrument by tilting in the direction indicated by arrow.

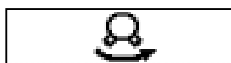

### Rotation warning indication

The instrument is tilted too far to the right or left.

Reposition the instrument to the direction indicated by arrow.

## 2 PREPARING FOR USE

### 2.1 Power Source

#### 2.1.1 Using On-board Battery of BT-53Q, DB-53

The on-board battery BT-53Q is a rechargeable system and the DB-53 is a disposable (dry) battery system. Refer to "POWER SOURCES AND CHARGING" for instruction on how to charge the BT-53Q, and how to replace the DB-53 dry batteries.

#### 2.1.2 Using 12 volt DC battery

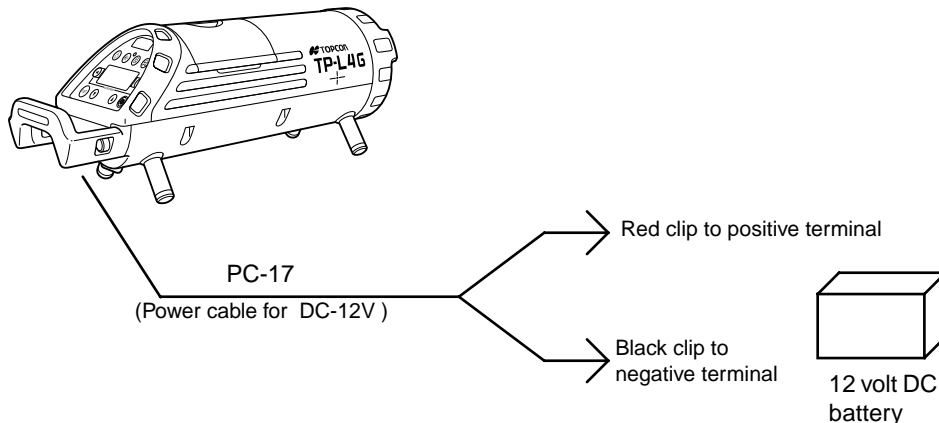

- Stop the engine while using automobile battery.
- Be sure to connect the red clip to positive terminal and black clip to negative terminal of the battery when using the Power source cable for 12 volt DC.  
(Electric current consumption: Max. 3A)

- Always turn OFF the instrument before removing on-board battery pack or external power cable.

#### Turning Power ON

Press the Power key. A company name (default; TOPCON) will be indicated for about five seconds.

(See "6 CHANGING OPERATING PARAMETERS" for instruction on how to change the company name.)

#### Security Mode

A four-digit security code can be set and activated to prevent unauthorized used.

When Security mode is set, the security code input is necessary when power is turned on (in Normal mode, Selecting mode and Checking and Adjusting mode).

(See Section "6 CHANGING OPERATING PARAMETERS" for instruction on how to set Security Mode.)

## 2.2 Setting TP-L4 (all models)

Always position the instrument so the bubble in the digital level vial is centered. The instrument has a self-leveling range of  $\pm 10\%$ . To assure proper self-leveling the instrument must be positioned to within 10% of the grade entered.

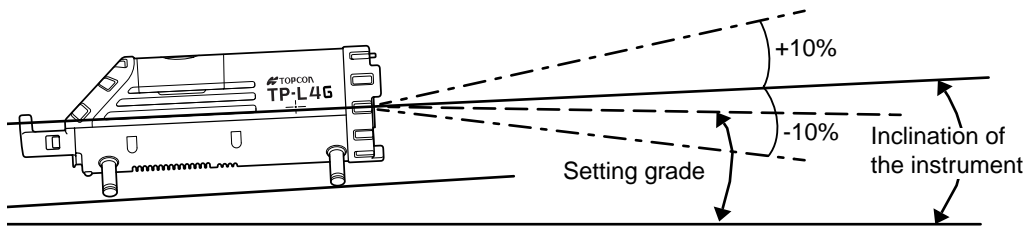

Level warning

When the instrument is not positioned within the self-leveling range, the level warning will appear. The laser blinks slowly. Reposition the instrument in the direction indicated by arrow.



Rotation warning

When the instrument is tilted beyond the rotation compensation range (approx.  $\pm 4^\circ$ ), the rotation warning will appear. The laser blinks slowly. Reposition the instrument by rotating it in the direction indicated by the arrow.



## 2.3 Grade setting procedure

### 2.3.1 Direct entry of grade value

(Example) Setting grade of +01.234% (+12.34Å) (Note: Å is a typo for % in the original image)

Be sure that the lock is disengaged before operating. (Format AB.CDE%)

Procedure	Key operation	Display
<b>1</b> Press [SET] key. The previous data will be shown, and ± mark blinks.	(SET)	-13.678%
<b>2</b> Press [▼] or [▲] key to change the sign to +.	(▼) OR (▲)	+13.678%
<b>3</b> Press [▶] key to shift to digit A.	(▶)	+13.678%
<b>4</b> Press [▼] or [▲] key to change value to "0".	(▼) OR (▲)	+03.678%
<b>5</b> Press [▶] key to shift to digit B.	(▶)	+03.678%
<b>6</b> Press [▼] or [▲] key to change value to "1".	(▼) OR (▲)	+01.678%
<b>7</b> Repeat previous steps to change values of digit C to "2", digit D to "3" and digit E to "4".	⋮ ⋮ ⋮	+01.234%
<b>8</b> Press [SET] key to desired grade. After entering, the instrument starts repositioning the laser to the grade. The Auto leveling indication blinks during the grade setting process. The laser beam blinks at the same time.	(SET)	SET
Åú Input range: -15.000% to 40.000% (-150.00~+400.00 Å)		

### 2.3.2 Set grade value by moving laser

Grade value can be set directly by moving laser up or down.

Be sure that the lock is disengaged before operating.

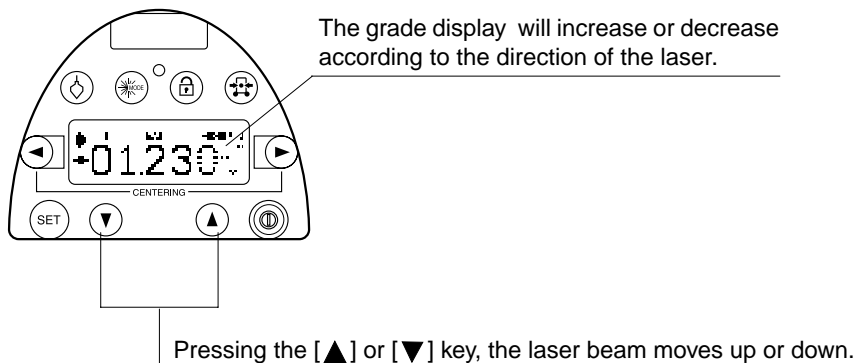

Zero Setting :Pressing the [▲] and [▼] key at the same time, the display and the laser will return to 0.00%.

## 2.4 Setting Laser Line

Use the line control key on the instrument display panel or the RC-200 remote control to move the horizontal laser position to the left or right required.

The maximum adjusting range is 9 m (29.5 ft.) at a distance of 30 m (100ft.)

The speed of the line travel is variable. When the key is first pressed, the speed will be slow. By pressing the key continuously, the speed of line travel will increase.

The relative position of the laser beam is shown on the display as indicated below.

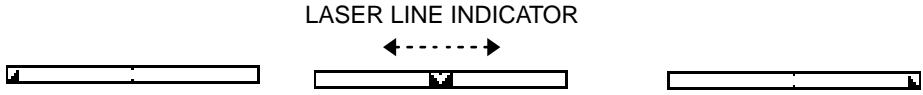

This display indicates that the laser line is positioned at the left end of the adjustment range. The laser line will not travel to the left even if the line control key is held down. In addition, the laser will blink to alert the user of this condition.

It is always a good idea to pre-position the laser to the center of its adjusting range prior to setup. (see below)

Maximum line adjust range

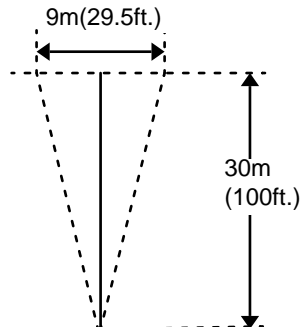

This display indicates that the laser line is positioned at the right end of the adjustment range. The laser line will not travel to the right even if the line control key is held down. In addition, the laser will blink to alert the user of this condition.

It is always a good idea to pre-position the laser to the center of its adjusting range prior to setup. (see below)



### 2.4.1 Automatic Centering

Press both line control left and right keys at the same time. The laser will return to the center of the line adjustment range automatically.

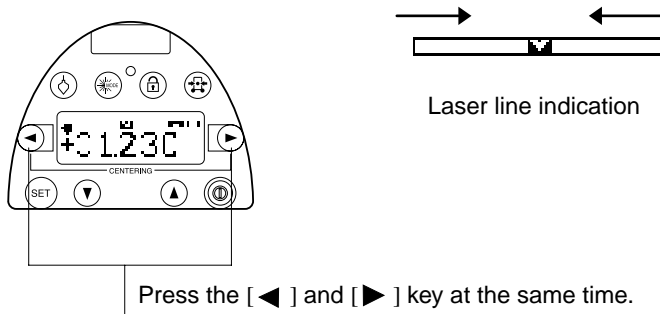

### 2.4.2 Automatic alignment with the target (TP-L4G and TP-L4A only)

This function is helpful for second day set ups. When the alignment is placed on centerline so it is in the alignment path of the beam, the laser will search the horizontal center of the target and automatically align the beam to it. Set the alignment target as follows and press the automatic alignment key on the instrument or the RC-200 remote control. The instrument starts auto alignment and the following display is shown.

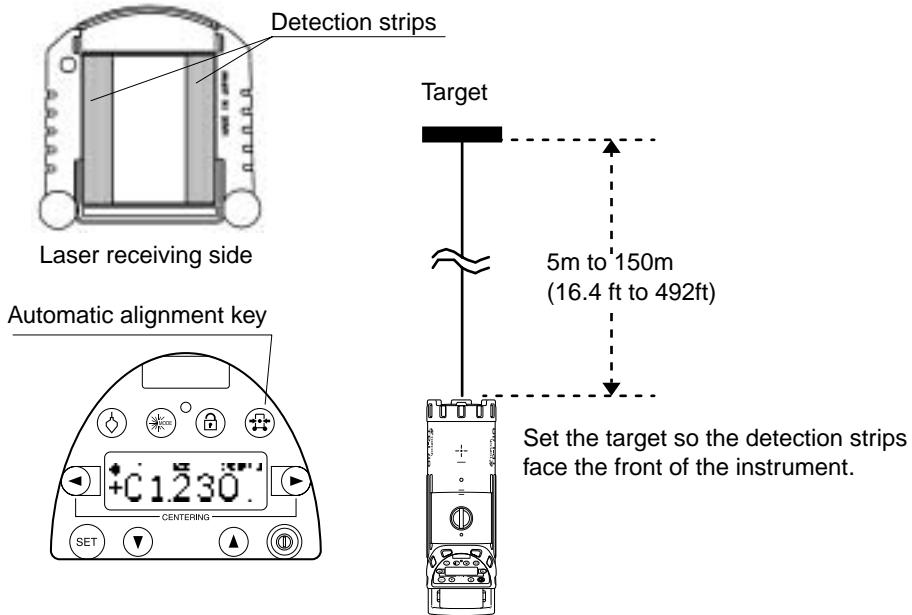

The display shows self leveling is in process. After self leveling is completed, automatic alignment starts.



The display shows stabilizing laser output after completing self leveling. When laser output is stable, automatic alignment starts. (Only on TP-L4G)



The display shows auto alignment is in process. Each step shows alignment progress.

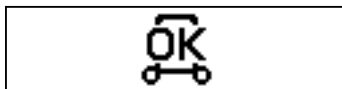
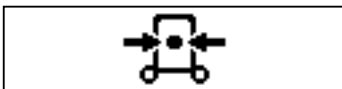

Alignment is completed. Confirm the laser beam on the target. If necessary, use the line control key or the remote control RC-200 and align the laser precisely.



Alignment target is lost during auto alignment mode. Re-set the instrument and press the automatic alignment key again.

## 2.5 Changing the laser beam mode

Two laser beam modes are available, ON and Blinking.

A third mode, High-Power, is available on green laser beam models.

By pressing the beam mode key, the beam mode will change alternatively.

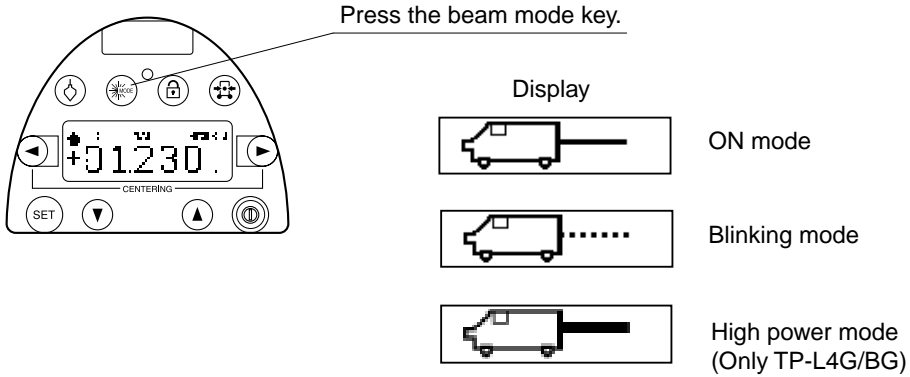

### TP-L4G and TP-L4BG Model Only:

The laser output is not stable for several minutes when the power is on or the mode of laser is changed. After the beam is stabilized (display does not show WAIT), the mode can be changed.

### 3 STANDARD ACCESSORIES

#### 3.1 Self Centering Feet and Single Point Foot

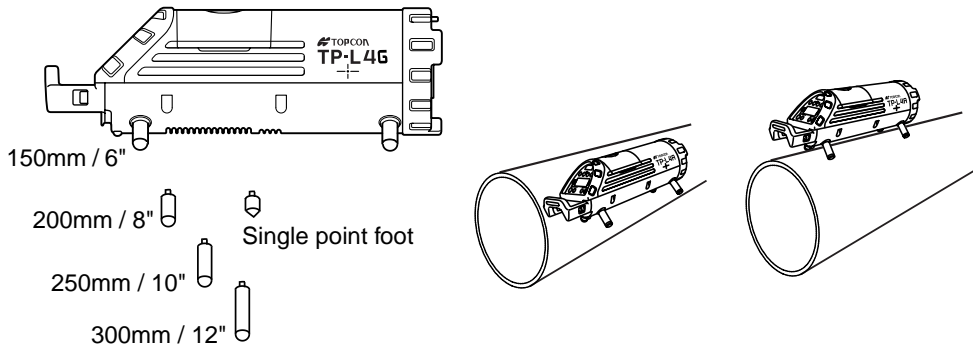

Four sets of centering feet are provided with the TP-L4. The feet provided with TP-L4 will center the laser beam inside the following diameters of pipe: 150mm(6"), 200mm(8"), 250mm(10") and 300mm(12")

They can also be used to set laser on top of the pipe or on a flat surface.

##### 3.1.1 Single point foot

Use the single pointed foot when the TP-L4 is unstable due to setting up on rough surfaces. It is possible to use two self-centering feet for 200 mm(8") diameter with the single point foot when the surface is level.

#### 3.2 Remote Controller, RC-200

The RC-200 allows you to remotely control most function of the TP-L4 as shown below. The RC-200 is convenient for aligning the beam while using a transit, or for saving power by temporarily putting the unit in standby mode using the ON/OFF switch.

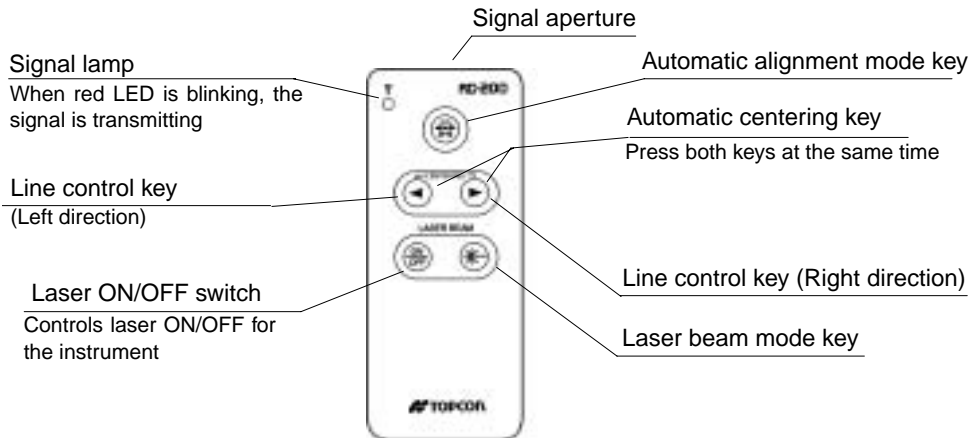

- Remote control operation is not possible when the instrument is locked. Press the lock key to release the lock function of the instrument.
- Operating range by remote control :Å@  
 Approx.200 m (656 ft.) (Though the pipe from a forward position)  
 Approx.25 m (82 ft.) (From above panel)
- The laser ON/OFF switch controls the laser beam only, not for the instrument. To turn power OFF to the instrument, be sure to switch OFF the instrument after operation is finished. When the laser is turned off by the laser ON/OFF switch, "STAND BY" is indicated on the display and the laser flashes once for five seconds.

Note:To turn laser beam ON again, press the laser ON/OFF switch for 2 seconds.

Laser line will travel in the direction of the line control keys when using the remote control from above or behind the panel position.

Laser line will travel in the opposite direction of the line control keys when using the remote control from a forward position.

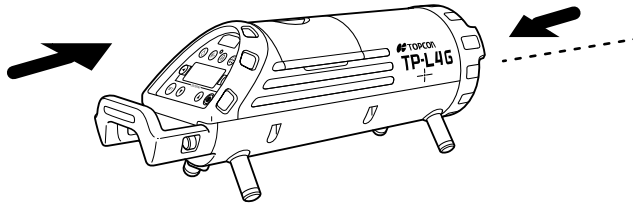

When using the remote controller, direct the signal aperture to the remote control receiving window on front of the TP-L4.

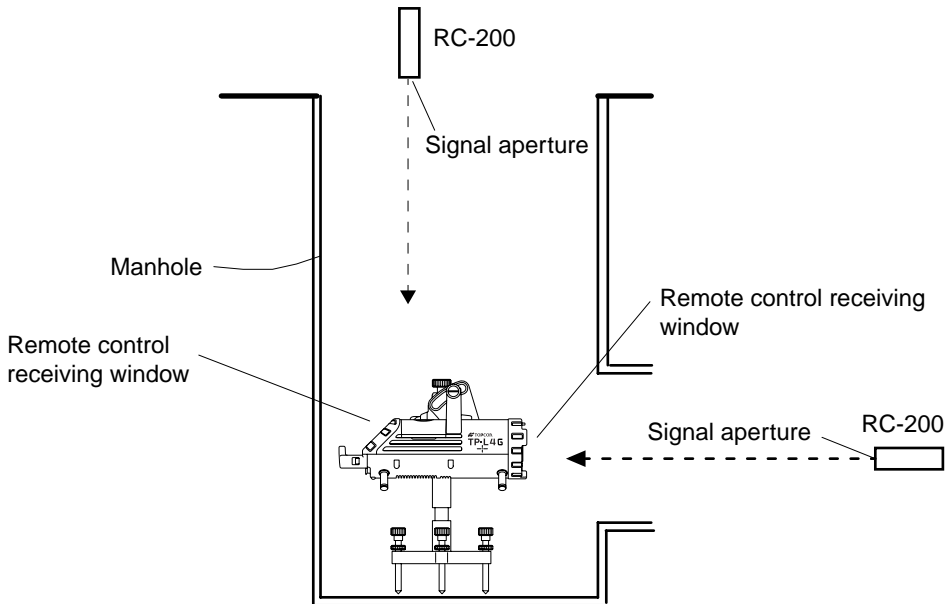

### 3.3 Safety Lock System

If the instrument is moved while it is in standby mode it will not be possible to turn the instrument back on from the remote control. This is to insure operational accuracy. In a situation such as this, "ERROR" will be displayed and laser beam will flash. To reset, turn power OFF then ON at the instrument.

### 3.4 Replacing battery for Remote Control, RC-200

- 1 Lift the battery cover on the back of the remote controller RC-200 is lifted up slightly by pressing toward the direction of the mark ▲. When the lid lifts up, take it out.
- 2 Replace the 4 old AAA alkaline batteries with new ones.
- 3 Click to close the lid by pressing on it.

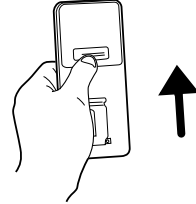

**Note**

- Replace all 4 batteries with new ones at the same time.
- Insert the batteries in the battery box according to the appointed direction.
- Do not mix used and new batteries, and do not mix different types of batteries together.

### 3.5 Target

Select the size of target assembly appropriate for the pipe diameter.

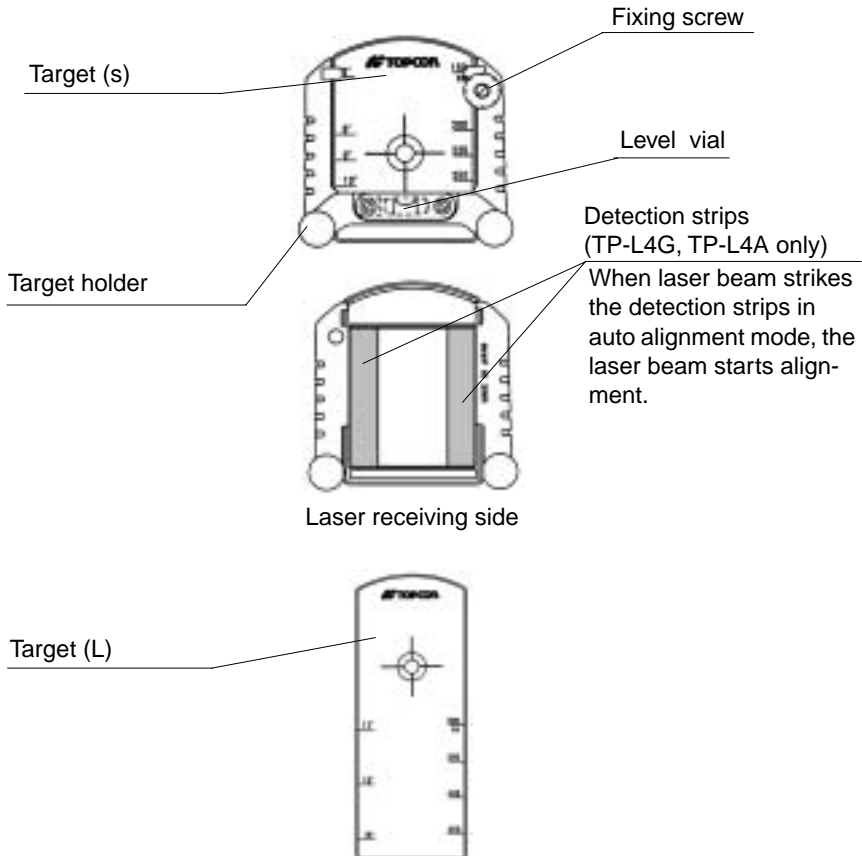

## 4 OPERATION EXAMPLE

### 4.1 Pipe Laying

#### Establish the Correct Elevation of the Laser

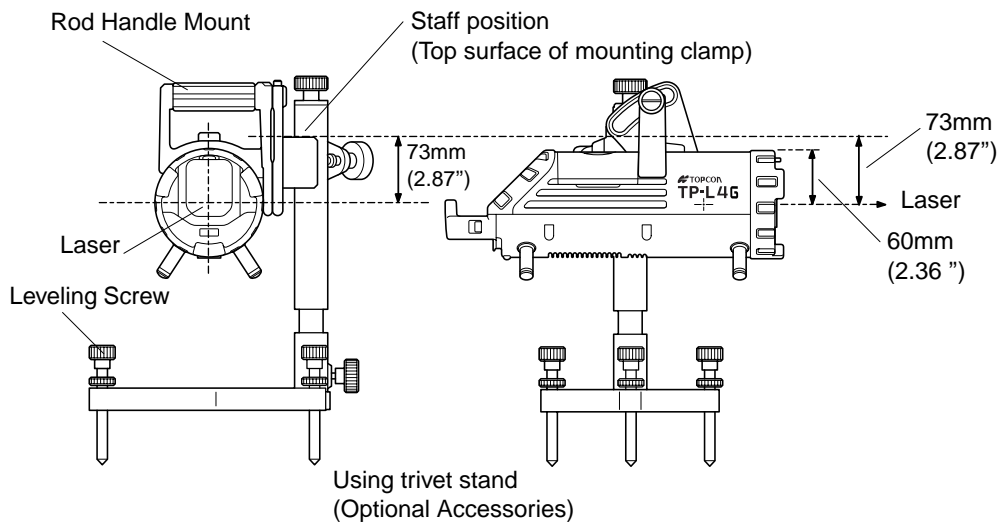

#### 4.1.1 Setting TP-L4G/A/B/BG

- 1** Attach the TP-L4G/A/B/BG to the trivet stand (Fig. 1a) and position the LED over center-line of the pipe or invert in the center of the manhole (Fig. 1b). By using three leveling screws, adjust the angle of the laser in direction indicated on the display until the bubble indicator is in the center position. For pre-poured inverts attach the appropriate sized feet and set the laser in the center of the invert (Fig. 1c).
- 2** Set up a level or rotating laser between the manhole and offset hub. Take a rod reading on the hub and add this reading to the cut indicated on the guard stake. (Fig. 2)
- 3** Place the grade rod on the top of the Rod Handle Mount clamp (if using leg set, elevation transfer is not necessary due to the fact that the pre-poured invert must be placed at the correct elevation). When measuring from the clamp, remember to add the offset distance to center the beam. (73mm or 2.87 inches) (Fig. 2)
- 4** Adjust the Trivet Rod using the height adjustment knob until the laser beam is at the correct elevation.

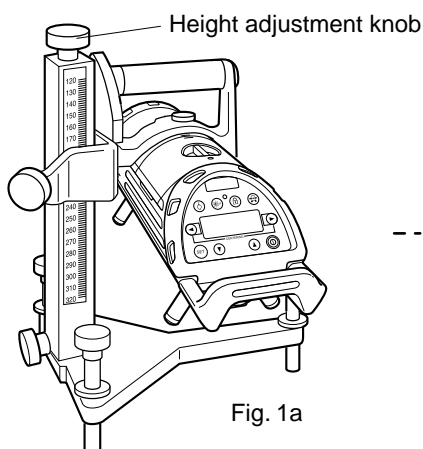

Fig. 1a

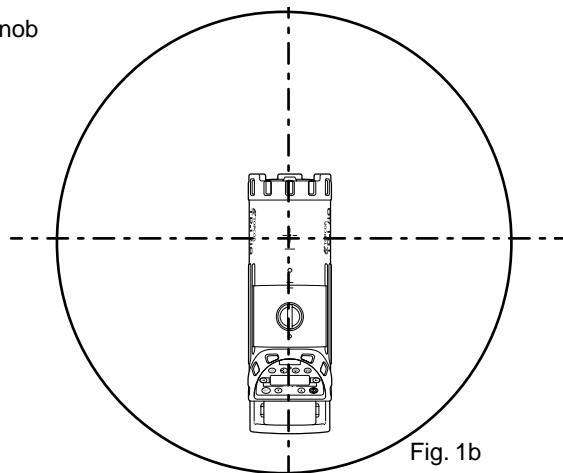

Fig. 1b



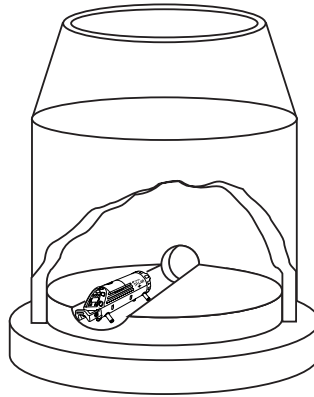

Fig. 1c

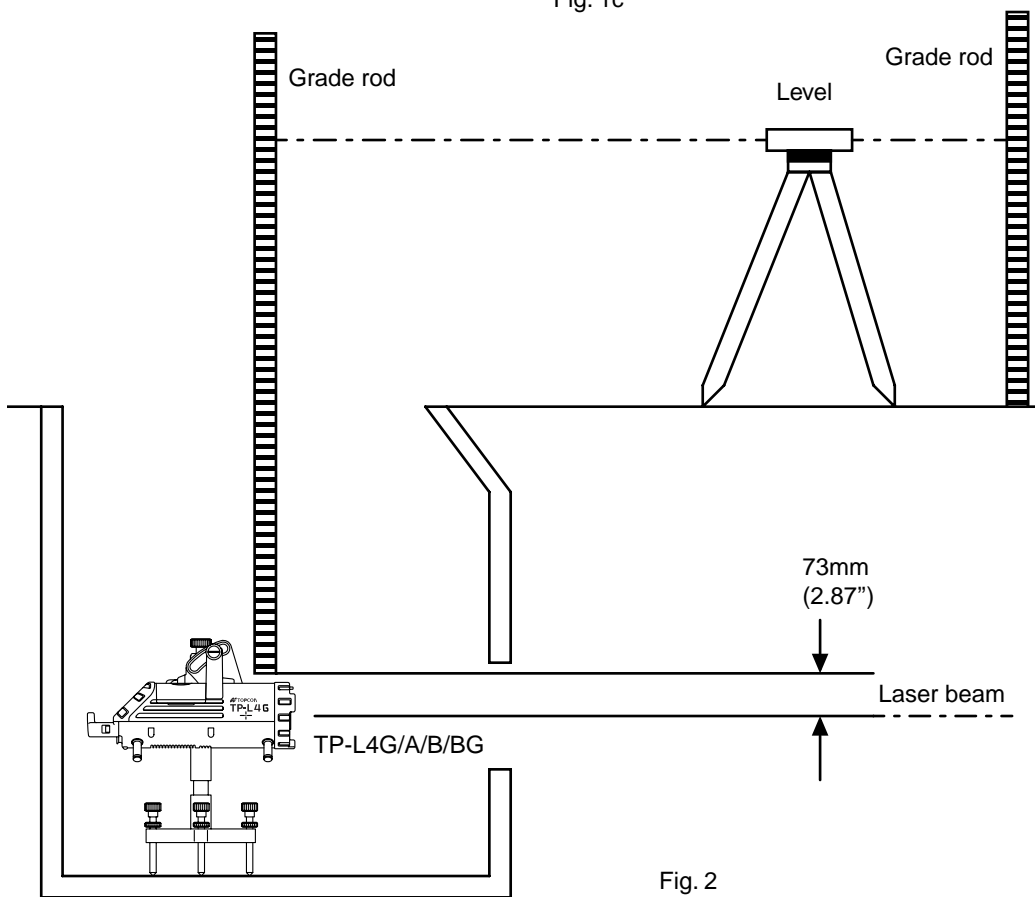

Fig. 2

#### 4.1.2 Setting grade

- 1 To set grade follow procedures as described in section "2.3 Grade setting procedure".

### 4.1.3 Setting line

#### Example 1

- 1** Position a transit directly over the centerline of the pipe using a plumb bob.
- 2** Align the transit to the forward manhole marker and then plummet the transit to view the bottom of the manhole. Position the laser so the LED is on the vertical cross hair of the transit.
- 3** Tilt the transit up so the view is forward into the base of the open ditch.
- 4** Use the RC-200 remote control to adjust the laser line until centered on the vertical cross hair of the transit.
- 5** Lay pipe.

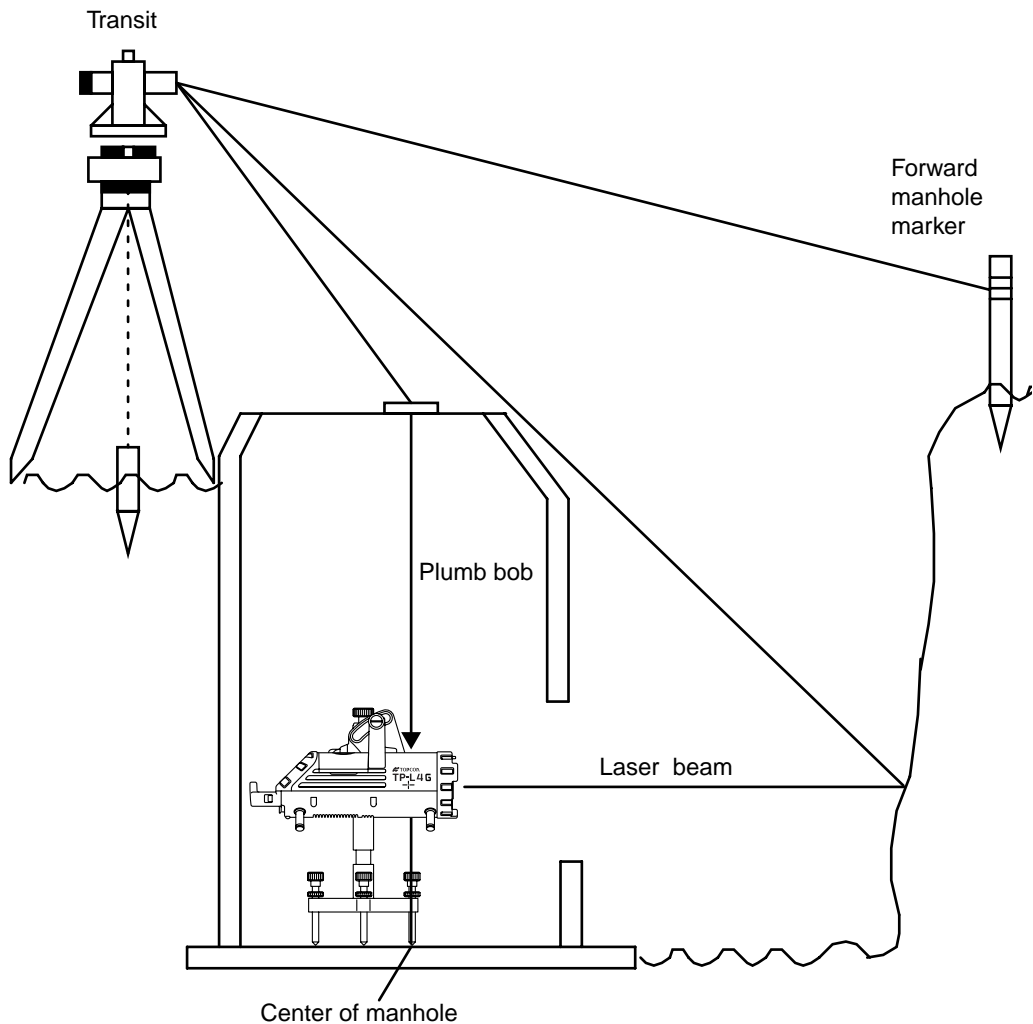

**Example 2**

- 1** Position the laser so it is centered in the manhole, over centerline of pipe.
- 2** Using the Manhole Transit Tower (optional), attach a transit and use a plumb bob to position it directly over the centerline LED on top of the laser and lock in place.
- 3** Align the transit to forward manhole marker.
- 4** Plumb the transit downward into the open excavation.
- 5** Align the laser beam to the transit using in RC-200 Remote Control.
- 6** Lay pipe.

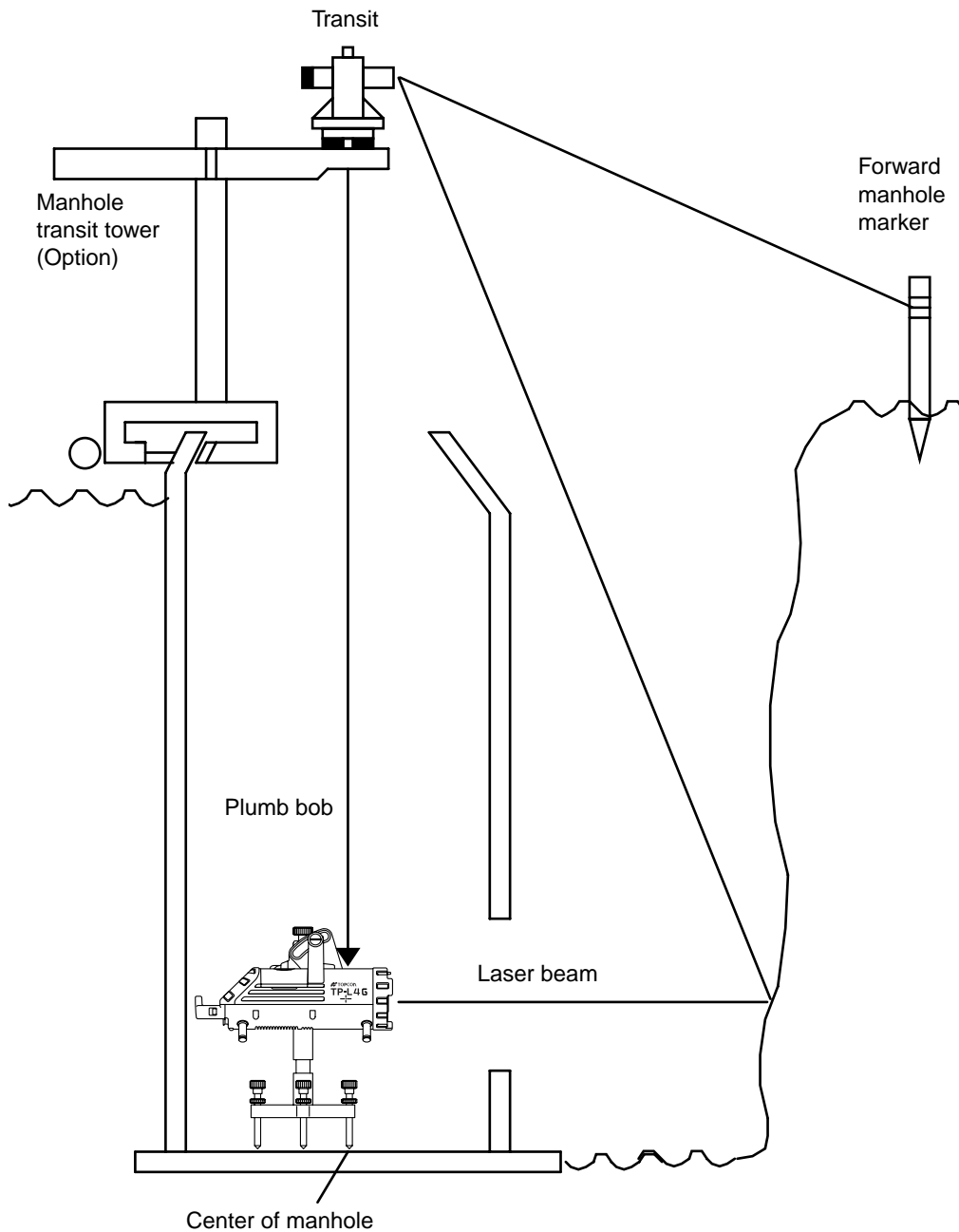

#### 4.1.4 Setting Excavation, Base Material and Pipe Elevation (Fig.5)

- 1 Calculate the base elevation from beam center as follows:

**Example:**

Pipe diameter: 300mm (12 inch)

Pipe thickness: 25mm (1 inch)

Base material: 150mm (6 inch)

**Distance from beam to base elevation**

Pipe radius: 300 divided by 2=150mm(12 divided by 2=6 in)

Pipe thickness: 25=25mm (1=1 in)

Base material: 150=150mm (6=6 in)

**Distance from beam to base elevation:**

150mm + 25mm + 150mm = 325mm

(6 in + 1 in + 6 in = 13 in)

- 2 Using a grade board or any reference rod you can now use the beam to control the depth of excavation by simply making a mark at the reference elevation (325mm or 13 in).

- 3 To set a sub-base elevation calculate the distance from the center of the beam as follows:

**Example:**

Beam Diameter: 300mm (12 inch)

Pipe Thickness : 25mm (1 inch)

**Distance from beam to sub base elevation.**

Pipe Radius: 300 divided by 2=150mm(12 divided by 2=6 in)

Pipe Thickness: 25mm=25mm(1inch=1inch)

**Distance from beam to sub-base elevation:**

150mm + 25mm = 175mm (6 in + 1 in = 7 in)

- 4 Using the grade board with the correct reference point (175mm or 7 inches) you can now control the elevation of the sub-base material.

- 5 To set pipe at the correct elevation simply set the pipe target for the correct size of pipe, place inside of the pipe and adjust the pipe until the laser beam is located precisely at the center "bull's-eye" on the target.

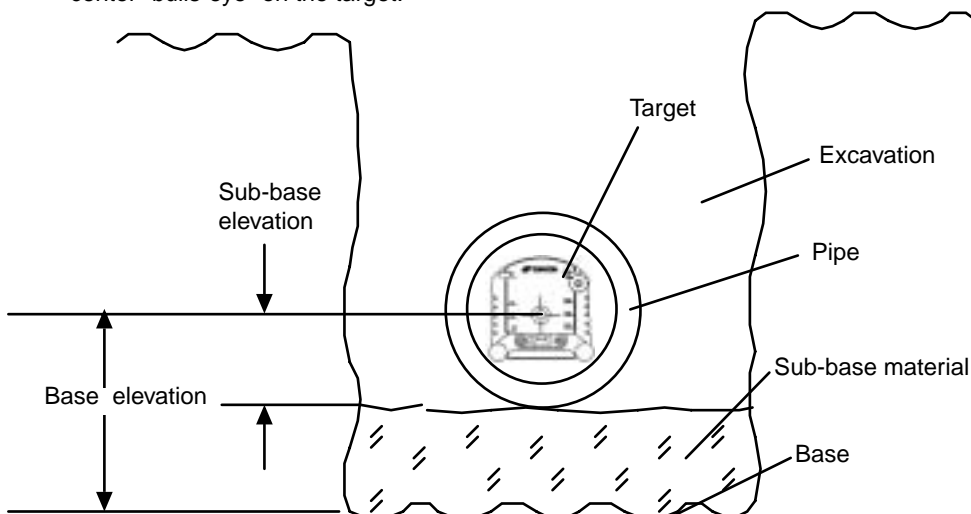

#### 4.1.5 In-the-Pipe Set up.

If some pipe distance has already been laid, the instrument can be set inside the pipe.

- 1** Attach the correct leg set for the appropriate pipe size.
- 2** Position the laser inside the pipe and adjust the rotation until bubble display is centered.
- 3** Locate the pipe target in the last section of pipe.
- 4** Using the RC-200 remote control or the alignment key on the control panel, automatically align the beam to the center of the target. The auto alignment function is available on the TP-L4G and TP-L4A models. For the TP-L4B/BG, use the alignment keys on the RC-200 remote control or on the control panel. Refer to “2 PREPARING FOR USE”.

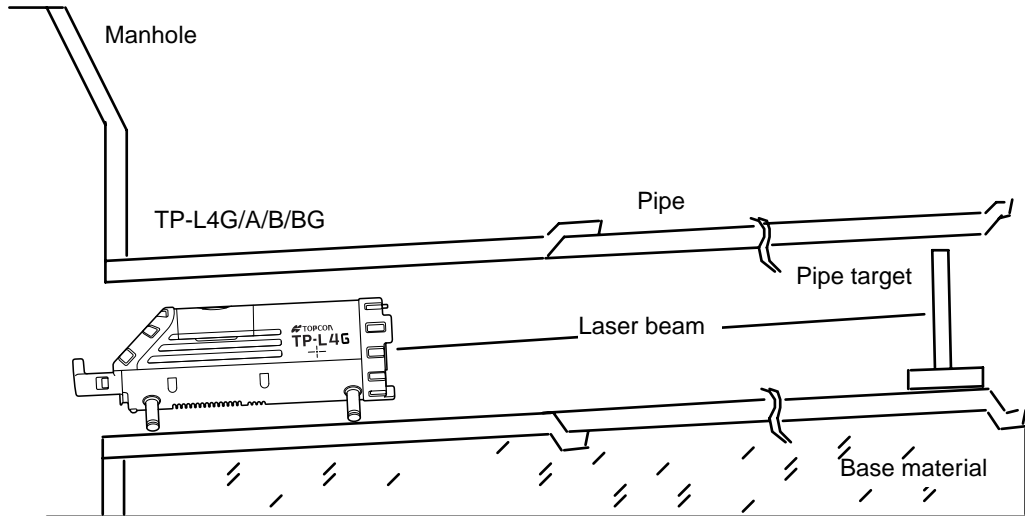

### 4.1.6 Grade Checking

After some pipe is layed (8 to 15m / 25 to 50 ft) you should check to make sure the laser has been set up for proper grade and line.

- 1** Determine the elevation of pipe starting point A, using transit or level and grade rod.
- 2** Determine the elevation of pipe end point B in the same manner.
- 3** The grade can be determined by subtracting the elevations of the two points (A minus B) divided by the horizontal distance between the two points.

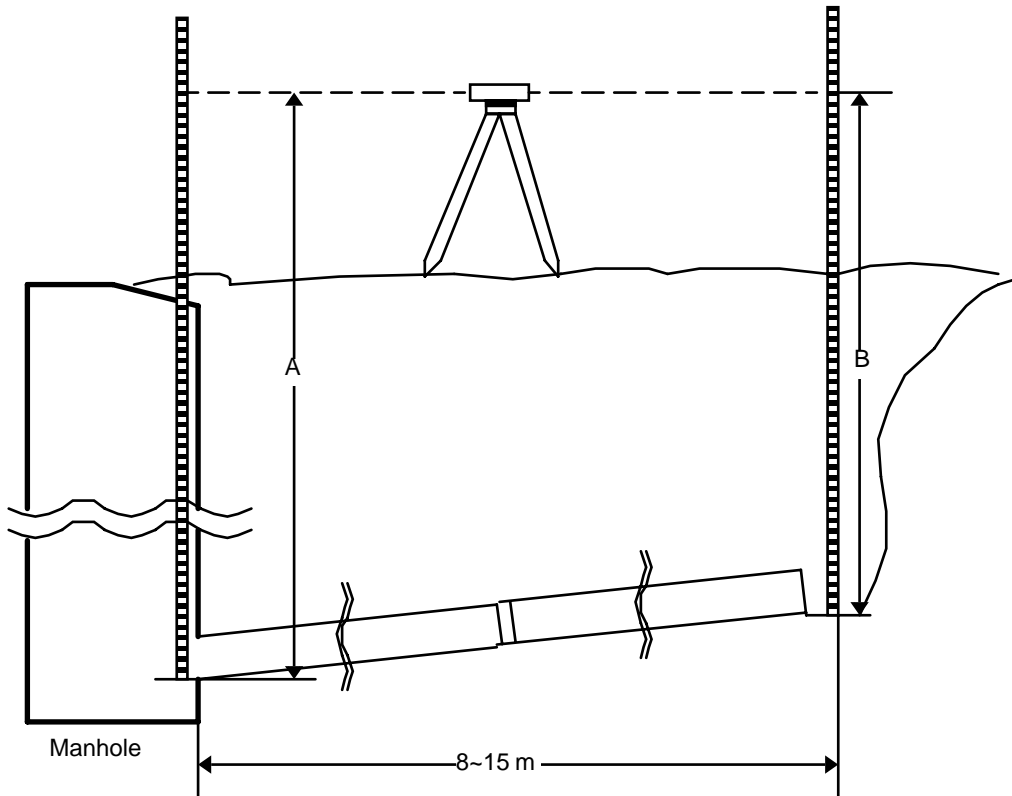

## 5 POWER SOURCE AND CHARGING

### 5.1 Dry battery (Alkaline) pack DB-53 (Optional Accessories)

#### 5.1.1 Removing

- 1 Turn the battery pack knob to "OPEN", lift and remove the battery DB-53.
- 2 Open battery pack by turning the lid knob to "OPEN".

#### 5.1.2 Replacing

- 1 Place the battery pack into the instrument. Pack will fit in only one orientation. If operator is on the panel side (back), the lettering should be right side up.
- 2 Secure by turning the knob to "LOCK".

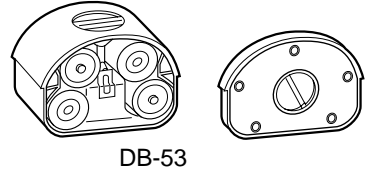

DB-53

#### Note

- Replace all 4 batteries with new ones at the same time.
- Insert the batteries in the battery box according to the appointed direction.
- Do not mix used and new batteries, and do not mix different types of batteries together.

### 5.2 Rechargeable battery pack BT-53Q

#### 5.2.1 Removing and Installing

- 1 Turn the battery pack knob to "OPEN", lift and remove the rechargeable battery pack BT-53Q.

#### 5.2.2 Charging

(Charging time: Approx. 9hours)

- 1 Insert the BA-2 battery adapter into the BT-53Q rechargeable battery as shown.
- 2 Plug the AC/DC converter into the BA-2.
- 3 Insert the AC/DC converter power cord into the appropriate AC outlet. LED of the BT-53Q rechargeable battery will light red.
- 4 When charging is complete, the LED will change to solid green. Unplug the BA-2 battery adapter from the BT-53Q.
- 5 Unplug the AC/DC converter power cord from the AC receptacle.

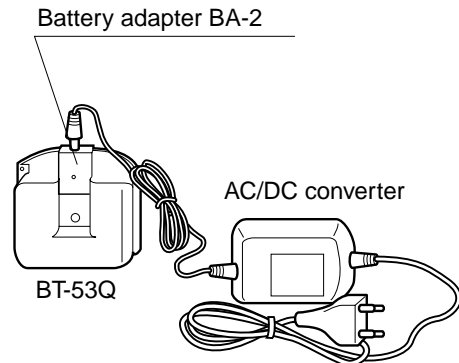

Note: To charge the battery, the following commercial AC/DC converter can be used.

Output: DC12V 1A

Inside diameter:  $\varnothing$  2.1mm

Outside diameter:  $\varnothing$  5.5mm



Note

- Recharging should take place in a room with an ambient temperature range of 10°C to 35°C (50°F to 95°F).
- Exceeding the specified charging time may shorten the life of the battery and should be avoided if possible.
- The battery source will discharge when stored and should be checked before using with instrument .
- Be sure to charge a stored battery source every 3 or 4 months and store in a place at 30 °C (86 °F) and below when it will not be used for a long period.  
If you allow the battery to be completely discharged, it will have an effect on the overall performance for proper charging in the future.
- Recharging can take less than 9 hours depending on the discharge condition of the battery when charging begins.

### 5.2.3 Charging while operating from DC 12V external battery

This function is useful when operating from the rechargeable battery pack (BT-53Q) that is low and needs charging. Using the instrument with 12VDC external battery in ambient temperature [+10°C to +35 °C (+50 °F to 95 °F)], the rechargeable battery pack can be recharged while the instrument is in use. Connect DC-12V external battery and turn the instrument ON, the charging indicator LED on top of the battery pack will indicate charging status.

The LED on the battery pack indicates charging status as follows:

Red ON:	Charging
Green ON:	Charging completed.
Green flashing:	Internal error of BT-53Q rechargeable battery
Red flashing:	BT-53Q rechargeable battery protection feature* is working automatically. The instrument can be used in this case.

\*Automatic protection feature:

In case of overcharge or high or low ambient temperatures that exceeds charging temperature range, charging will be stopped or changed to protect battery.

If the 12VDC external battery is disconnected while working, the power source will automatically switch to the rechargeable battery pack (BT-53Q).



## 6 CHANGING OPERATING PARAMETERS

### 6.1 Operating Parameters











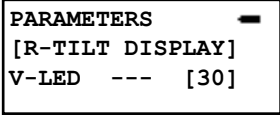

The standard (default) setting for several operating parameters of the TP-L4 can be changed by the user. This table below lists the operating parameters that can be changed, the stand default setting and optional settings for each one.

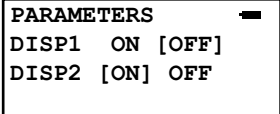
Parameter	Options [default]	Description
<b>R-TILT DISPLAY</b> (level vial indicator)		Selects whether or not to enlarge the level vial indicator on the display when the unit is first turned on or when the unit is tilted.
<b>DISP1</b>	<b>ON / [OFF]</b>	DISP1: default OFF When this parameter is set to ON, the level vial indicator is enlarged when the instrument is off and the power key is first pressed. The power key must be pressed again to turn instrument on.
<b>DISP2</b>	<b>[ON] / OFF</b>	DISP2: default ON The level vial indicator enlarges to fill the display anytime the TP-L4 is tilted. The display returns to normal when the instrument is properly positioned or when any other control key is pressed.
<b>V -LED</b>	<b>--- / [30]</b>	Selects automatic cut-off parameter for the center-line (vertical) LED indicator on top of instrument. --- : Automatic cut-off is disabled. LED remains on whenever after being turned on by user.  30 : Default setting. Centerline LED automatically cuts off 30 minutes after it has been turned on by user (see page 1-2).
<b>UNIT</b>	<b>[%] / ÅÒ</b>	Selects how grade is displayed, in percent (%) or per milli (ÅÒ). % : Default setting. Grade is displayed to the nearest thousandths of a percent (+01.235%) ÅÒ : Grade is displayed as per milli [+01.235% (percent) equals +012.35ÅÒ (per milli)]
<b>S CODE</b>	<b>ON / [OFF]</b>	Activates security code function. Default is OFF. Changing to ON requires the entry of a 4-digit security to turn on instrument.
<b>CHANGE S CODE</b>	<b>(no preset code)</b>	Allows user to input any 4-digit security code after S CODE is set to ON.
<b>CHANGE NAME</b>	<b>(TOPCON preset)</b>	Allows user to enter name that will display during power-up. Default name is TOPCON.

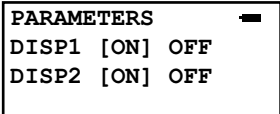
## 6.2 How To Change Operating Parameters

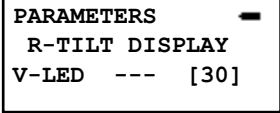
### EXAMPLE

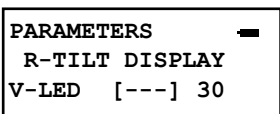
Change R-TILT DISPLAY, DISP1 from OFF to ON and disable the V-LED automatic cut-off.

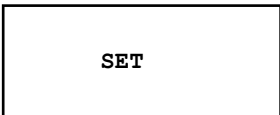
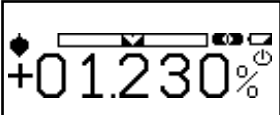





















Procedure	Key operation	Display
<b>1</b> Press Power ON key while pressing and holding the Lock key  . The R-TILT DISPLAY is the first parameter setting.	 +Power ON	
<b>2</b> Press [SET] to select R-TILT DISPLAY.		
<b>3</b> The DISP1 parameter flashes to show it is active. Press [  ] key to select [ON] for DISP1.		
<b>4</b> Press [SET] key to accept new setting.		
<b>5</b> Press [  ] key to select [---].		
<b>6</b> Press [SET] key to accept new setting.		
Display will change to operating mode. The unit will now operate with the new parameter settings (level vial indicator enlarged on power-up and centerline LED always on).		

### 6.3 How to Input (Change) Security Code

To prevent unauthorized use of the TP-L4 a four-digit security can be set. The following table describes how to activate the security mode (S CODE) and select a four-digit code. When Security mode is set, it is necessary to input the code every time power is turned on (in Normal mode, Selecting mode and Checking & Adjusting mode).

**IMPORTANT:**

Memorize the security code and file it in a safe place. It is not possible to operate the TP-L4 without entering the code.

Procedure	Key operation	Display
<b>1</b> Press and hold down lock key  while turning power on. (see note 1 on next page) <i>(text in [brackets] indicates present setting)</i>	 +Power ON	<b>PARAMETERS</b> [R-TILT DISPLAY] V-LED --- [30]
<b>2</b> Select "CHANGE S CODE" (If first time to set code, "INPUT S CODE" is indicated.) by pressing the [  ] key four times.	 4 times	<b>PARAMETERS</b> S CODE [ON]OFF [CHANGE S CODE ]
<b>3</b> Press [SET] key. (see note 2)		ENTER 01234 SECURITY 56789 CODE [____] SET
<b>4</b> Select a numeric character by pressing the [  ,  ,  ,  ] keys. Example: 7	 OR   OR 	ENTER 01234 SECURITY 56789 CODE [____] SET
<b>5</b> Press [SET] key.		ENTER 01234 SECURITY 56789 CODE [7____] SET
<b>6</b> Repeat steps <b>4</b> and <b>5</b> to set remaining three code numbers. Example: 7777 (see note 3)		ENTER 01234 SECURITY 56789 CODE [7777] SET
<b>7</b> Select "SET" by pressing the [  ,  ,  ,  ] keys.	 OR   OR 	ENTER 01234 SECURITY 56789 CODE [7777] <u>SET</u>
<b>8</b> Press [SET] key.		SECURITY CODE SET
The display returns to menu.		↓ <b>PARAMETERS</b> S CODE [ON]OFF CHANGE S CODE





















### 6.4 How to Change Company Name

The company name displayed during power-up can be changed.

The following characters can be used:

Numeric digits 0 to 9; capital letters A to Z; period; comma; apostrophe; space; opened and closed parenthesis.

Maximum of 32 characters can be input (2 lines of 16 characters each).

Procedure	Key operation	Display
<p><b>1</b> Press and hold down lock key  while power is turned on. (see note 1 on next page) (text in [brackets] indicates present setting)</p>	<p> +Power ON</p>	<div style="border: 1px solid black; padding: 5px;"> <p>PARAMETERS [R-TILT DISPLAY] V-LED --- [30]</p> </div>
<p><b>2</b> Press the down arrow key five  times to scroll to CHANGE NAME.</p>	<p> 5 times</p>	<div style="border: 1px solid black; padding: 5px;"> <p>PARAMETERS CHANGE S CODE [CHANGE NAME]</p> </div>
<p><b>3</b> Press [SET] key. (see note 2)</p>	<p></p>	<div style="border: 1px solid black; padding: 5px;"> <p>COMPANY NAME ENTER NEW NAME</p> </div>
<p><b>4</b> Select a character string by pressing the  or  keys.</p>	<p> OR </p>	<div style="border: 1px solid black; padding: 5px;"> <p style="text-align: center;">↓</p> <p>TOPCON _____ ABCDEFGHIJ&lt;--&gt;SET</p> <p style="border: 1px dashed black; padding: 2px;">KLMNOPQRST&lt;--&gt;SET UVWXYZ . / &lt;--&gt;SET ( ) 01234567&lt;--&gt;SET 89 &lt;--&gt;SET</p> </div>
<p><b>5</b> Select a character in the character string by pressing the  or  keys. Example; LASER(1)</p>	<p> OR </p>	<div style="border: 1px solid black; padding: 5px;"> <p>TOPCON _____ KLMNOPQRST&lt;--&gt;SET</p> </div>
<p><b>6</b> Press [SET] key.</p>	<p></p>	<div style="border: 1px solid black; padding: 5px;"> <p>LOPCON _____ KLMNOPQRST&lt;--&gt;SET</p> </div>
<p><b>7</b> Repeat procedures <b>4</b> to <b>6</b> until complete. (see note 3 on next page)</p>		<div style="border: 1px solid black; padding: 5px;"> <p>LASER (1) _____ ( ) 01234567&lt;--&gt;SET ( ) 01234567&lt;--&gt;SET</p> </div>
<p><b>8</b> Select "SET" by pressing the  or  keys.</p>	<p> OR </p>	
<p><b>9</b> Press [SET] key.</p>	<p></p>	<div style="border: 1px solid black; padding: 5px;"> <p>COMPANY NAME  SET</p> </div>

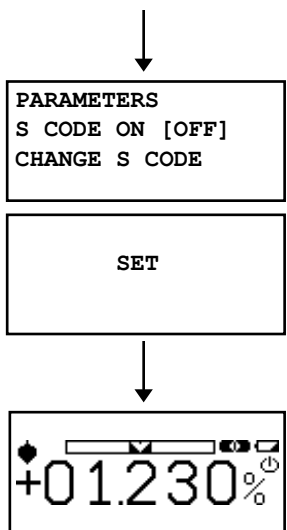
<p>The display returns to menu.</p> <p><b>10</b> Press [SET] key.</p> <p>The instrument returns to normal mode.</p>		
---	---	--

- Note 1) When security mode is ON, the security code must be input to operate.
- Note 2) When security code has been entered, but security mode is OFF, input of current security code is necessary to change security code.
- Note 3) Follow the steps below if it's necessary to correct a character during input.

**How to correct a character**

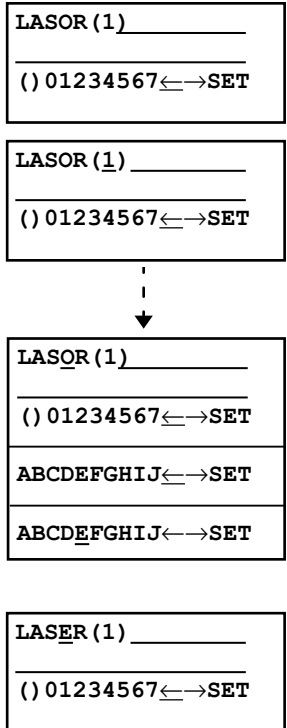
<p><b>1</b> Select the left or right arrow by pressing the [◀] or [▶] keys.</p> <p><b>2</b> Press [SET] key. The underline (cursor) moves to left or right by pressing the [SET] key.</p> <p><b>3</b> Select a character string by pressing the [▼] or [▲] keys.</p> <p><b>4</b> Select a character in the character string by pressing the [◀] or [▶] keys.</p> <p><b>5</b> Press [SET] key.</p> <p>Repeat steps <b>1</b> to <b>5</b> to correct other characters.</p>		
---	--	---

# 7 CHECKING AND ADJUSTING CALIBRATION

## 7.1 Procedure To Check and Adjust Laser Calibration

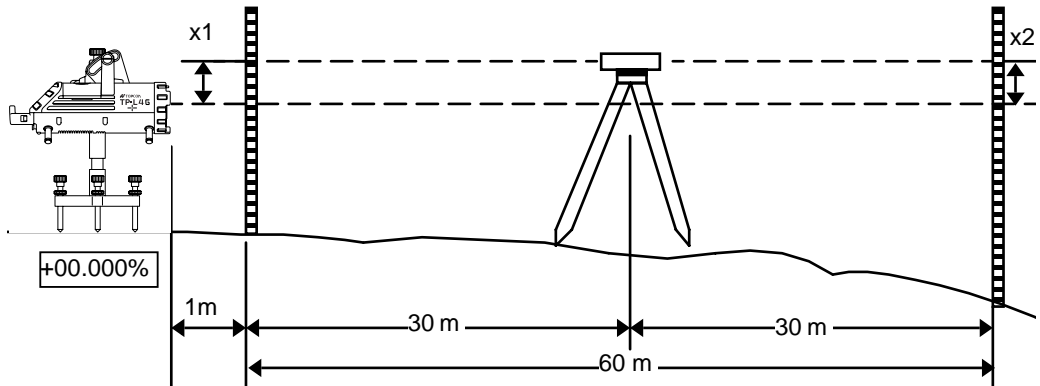

### 7.1.1 Checking Calibration

- 1** Make sure grade is set to 00.000% or 000.00%.
- 2** Locate control points directly beneath the laser beam 1m (3.3 ft) in front of the TP-L4 and 60m (197ft.) from the first control point (see illustration above).
- 3** Set up a transit or level midway between the 1st and 2nd control points.
- 4** Take elevation readings at both control points using the laser beam and the transit or level. If the distance between the readings at each point (x1 and x2) are the same, the unit does not need adjustment. If x1 and x2 are not the same, the unit requires adjustment as follows.

### 7.1.2 Adjusting Calibration

Procedure	Key operation	Display
<b>1</b> When checking is finished, turn the power OFF.	Power OFF	
<b>2</b> Press and hold [SET] key while turning power ON.	(SET) + Power ON	0 SET
<b>3</b> Press the [SET] key.	(SET)	INIT LASER
<b>4</b> Adjust the height of laser beam until x1 and x2 measurements are equal (use [▼] or [▲] key).	(▼) or (▲)	
<b>5</b> After the display stops flashing "LASER", press the [SET] key*.	(SET)	WAIT ↓ +00000
<b>6</b> When +00000 appears on the display, press the [SET] key again. Turn power OFF.	(SET)	END ↓ +00000
Repeat checking procedure above to confirm accurate calibration.		

\* If the adjustment range is exceeded, "E72"(error) will be displayed in step **5** . Repeat checking and adjusting procedure. If the error continues, contact dealer or Topcon.

## 8 ERROR DISPLAYS

Error Code	Contents	Countermeasure
E02 E03	Abnormal operation of internal measuring system.	Switch OFF the power, then ON again. Excessive vibration around the laser may cause this error. Eliminate vibration.
E72	Indicates excessive tilt of the laser instrument during calibration checking or adjusting.	Switch OFF the power. Set the instrument level then repeat checking and adjusting calibration procedure.
E86 E87	Internal communication error	Switch OFF the power, then ON again.
E99	Abnormal operation of internal memory system detected.	Switch OFF the power, then ON again.

If error code remains after trying countermeasures above, please contact your Topcon dealer.



## 9 TROUBLESHOOTING

Check to see the instrument referring to the error list or the following troubleshooting list when you notice the failure of the instrument.

If the instrument can't be recovered or the failure isn't written in the following list, please contact your local Topcon dealer.

Conditions	Causes	Countermeasures
1. Laser beam does not emit	1) Battery level is low. 2) Improper connection to an external power source (such as a 12 volt DC battery). 3) The laser is turned off because the laser ON/OFF switch of the remote controller is pushed.	1) Recharge or replace the batteries with new ones. 2) Make sure connection is secure and attached to correct terminals. 3) Push the laser ON/OFF switch of the remote controller, then the laser is turned on.
2. Laser beam blinks	1) When Level Warning Indicator blinks, the instrument is tilted beyond the self-leveling range (laser blinks slowly). 2) Any shock or vibration to the unit produces unstable condition causing beam to blink.	1) Reposition the instrument until the level warning indicator disappears. 2) Eliminate the source of disturbance to the unit.
3. Laser beam emits but grade setting is not possible	1) The instrument is in lock mode. 2) The value entered is out of the grade range. 3) When Level Warning Indicator blinks, the instrument is tilted beyond the self-leveling range (laser blinks slowly). 4) Battery level is low.	1) Press the lock key on the instrument to release the lock function. 2) Grade entry must be between 15%~+40%. 3) Reposition the instrument until the level warning indicator disappears. 4) Recharge or replace the batteries with new ones.
4. Laser beam emits but line setting is not possible.	1) The instrument is in lock mode. 2) The laser beam has reached the limit of line adjusting range.	1) Press the lock key on the instrument to release the lock function. 2) Center the line adjustment and aim instrument so laser is roughly aimed at target.
5. Remote control does not function.	1) The instrument is in lock mode. 2) The battery power of remote control is low.	1) Press the lock key on the instrument to release the lock function. 2) Replace the batteries.

6. The laser beam is unstable.	<ol style="list-style-type: none"> <li>1) The laser beam is refracted due to temperature differences within the pipe.</li> <li>2) The laser beam is refracting and reflecting due to fog and/or mist.</li> </ol>	<ol style="list-style-type: none"> <li>1) When the pipe is laid, the trench must be backfilled immediately to help maintain temperature stability.</li> <li>2) Use a blower (optional accessory) to move air through the pipe to blend the air and remove mist or fog. <ul style="list-style-type: none"> <li>• Cover the pipe to prevent heat build up inside the pipe before laying.</li> <li>• Clear the mist or fog.</li> </ul> </li> </ol>
7. The laser position shifts over time passed.	<ol style="list-style-type: none"> <li>1) The pipe may be sinking.</li> <li>2) The target is not securely held.</li> </ol>	<ol style="list-style-type: none"> <li>1) Confirm the pipe grade setting using a level.</li> <li>2) Secure the target within its holder.</li> </ol>
8. The grade setting value of the TP-L4 and the measured grade value are not equal.	<ol style="list-style-type: none"> <li>1) Incorrect grade value was entered.</li> <li>2) The bubble on the bubble tube display of the instrument or the bubble on the target was not adjusted correctly.</li> <li>3) The laser beam is refracted due to temperature differences within the pipe.</li> </ol>	<ol style="list-style-type: none"> <li>1) Confirm the input value (% or %) and reset.</li> <li>2) Adjust the laser and/or target so the bubble is centered.</li> <li>3) When the pipe is laid, the trench must be backfilled immediately to help maintain temperature stability. Use a blower (optional accessory) to move air through the pipe to keep temperature and moisture stable.</li> </ol>
9. The charging lamp of the internal battery BT-53Q is blinking slowly when connected to the DC-12V external battery. (Error blinking)	<ol style="list-style-type: none"> <li>1) The charging temperature is out of range.</li> <li>2) The battery BT-53Q is completely discharged.</li> </ol>	<ol style="list-style-type: none"> <li>1) Recharging should take place in the temperature range of 10°C to 35°C (50°F to 95°F).</li> <li>2) Continue the charging for 30 minutes. <ul style="list-style-type: none"> <li>• If the lamp changes to red light -up mode, the battery is normal.</li> <li>• If the lamp continues green blinking, battery is faulty and must be replaced. Always properly dispose old battery.</li> </ul> </li> </ol>

# 10 OPTIONAL ACCESSORIES

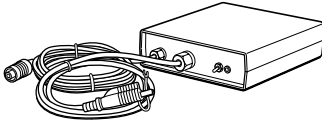

AC/DC Converter model 2

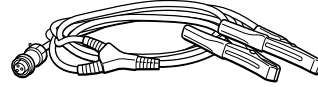

Power cable for 12VDC PC-17

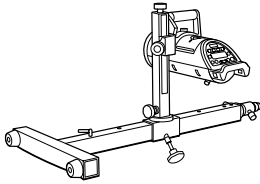

Drop manhole kit model 5

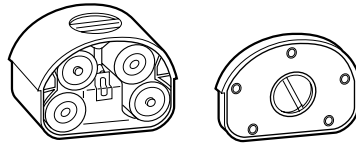

Dry battery holder DB-53

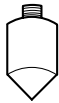

Single pointed foot model 2

Trivet handle model 2

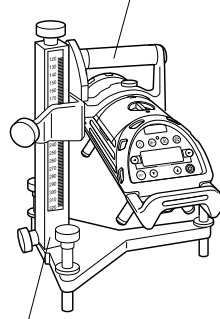

Trivet stand model 3

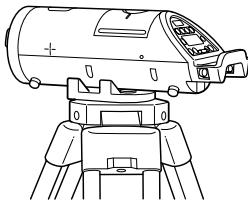

Tripod adapter model 3

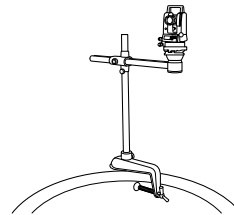

Transit tower kit model 2

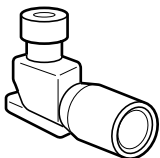

Scope model 2

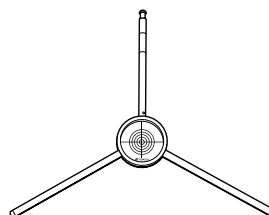

Target (Large)

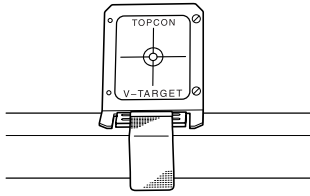

Vertical target model 2

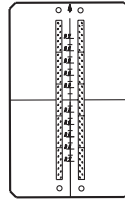

Over the top target

These accessories should be available through the same Topcon dealer that supplied the TP-L4. Other accessories may also be available.

# 11 SPECIFICATIONS

## TP-L4G/A/B/BG

Light source	: Visible laser diode
Wave length	: 532nm (TP-L4G/BG, green) 633nm (TP-L4A/B, red)
Laser power output	: 2.8mW(Max.)
Laser diameter	: $\varnothing$ 12mm
Line control width	: $\pm$ 15% ( $\pm$ 15 ft and 100 ft distance)
Grade readout	: -15% ~ +40% (-150 ‰ ~ +400 ‰)
Minimum setting of grade	: 0.001%
Grade setting method	: Absolute encoder
Self leveling range	
Slope direction	: $\pm$ 10%
Axis direction	: Approx. $\pm$ 4 $\mu$ K
Horizontal accuracy	: $\pm$ 10 arc seconds
Automatic alignment distance	: 5m ~150 m/16.5 ft ~ 492 ft (TP-L4G/A)
Operating time [+20°C (+68°F)]	
TP-L4G/BG	: DB-53:Approx. 45 hours (Using alkaline manganese dry batteries) BT-53Q:Approx.32 hours
TP-L4A/B	: DB-53:Approx.70 hours (Using alkaline manganese dry batteries) BT-53Q:Approx.48 hours
Operating temperature	: -20°C ~ +50 °C (-4°F to 122°F)
Dimensions	: $\varnothing$ 122mm ~ 330mm/ 4.8 in ~ 13 in (Without handle) $\varnothing$ 125mm ~ 374mm / 4.9 in ~ 14.7 in (with rear handle)
Weight	: Approx. 3.8kg (8.21lbs)

## Remote controller Model RC-200

Operating distance	: Through the pipe from front, approx.200m (624ft.)
Functions	: Line control, Laser beam ON/OFF, Laser beam mode, Automatic alignment mode, Line centering
Power supply	: Four AAA size dry batteries
Operating time	: Approx. 8 months (Using alkaline manganese dry batteries)



### EMC NOTICE

In industrial locations or in proximity to industrial power installations, this instrument might be affected by electromagnetic noise. Under such conditions, please test the instrument performance before use.



PIPE LASER

# TP-L4<sub>SERIES</sub>

---

**TOPCON LASER SYSTEMS, INC.**

5758 West Las Positas Blvd., Pleasanton, CA 94588, U.S.A.  
Phone: 925-460-1300 Fax: 925-460-1315 [www.topconlaser.com](http://www.topconlaser.com)

**CORPORATE OFFICE**

37 West Century Road, Paramus, New Jersey 07652, U.S.A.  
Phone: 201-261-9450 Fax: 201-387-2710 [www.Topcon.com](http://www.Topcon.com)

**TOPCON CALIFORNIA**

3380 Industrial BLVD, Suite 105, West Sacramento, CA 95691, U.S.A.

Phone: 916-374-8575 Fax: 916-374-8329

**TOPCON MIDWEST**

891 Busse Road, Elk Grove Village, IL 60007, U.S.A.  
Phone: 847-734-1700 Fax: 847-734-1712

**TOPCON EUROPE B.V.**

Esse Baan 11, 2908 LJ Capelle a/d IJssel, The Netherlands.  
Phone: 010-4585077 Fax: 010-4585045 [www.topconeurope.com](http://www.topconeurope.com)

**TOPCON BELGIUM**

Preenakker 8, 1785 Merchtem, Belgium  
Phone: 052-37.45.48 Fax: 052-37.45.79

**TOPCON DEUTSCHLAND G.m.b.H.**

Weidkamp 180 45356 Essen, Germany.  
Phone: 001-49-201-8619-150 Fax: 001-49-201-8619-148

**TOPCON S.A.R.L.**

89, rue de Paris 92585 Clichy, Cedex France.  
Phone: 01-4106 9494 (MEDICAL) 1-4106 9490 (TOPOGRAPHIE)  
Fax: 01-47390251

**TOPCON ESPAÑA S.A.**

**HEAD OFFICE**  
Frederic Mompou 5, ED. EUR03 08960, Sant Just Desvern Barcelona, Spain.  
Phone: 93-473-4057 Fax: 93-473-3932

**MADRID OFFICE**

Avenida Burgos,16E, 1° 28036, Madrid, Spain.  
Phone: 91-302-4129 Fax: 91-383-3890

**TOPCON SCANDINAVIA A. B.**

Neogatan 2 S-43151 Molndal Sweden.  
Phone: 001-46-31-7109200 Fax: 001-46-31-7109249

**TOPCON (GREAT BRITAIN) LTD.**

Topcon House Kennet Side, Bone Lane Newbury Berkshire RG14 5PX U.K. Phone: 001-44-1635-551120 Fax: 001-44-1635-551170

**TOPCON SINGAPORE PTE. LTD.**

Alexandra Distripark Block 4, #05-15, Pasir Panjang Road, Singapore 118491  
Phone: 2780222 Fax: 2733540 E-mail: [topconts@singnet.com.sg](mailto:topconts@singnet.com.sg)

**TOPCON AUSTRALIA PTY. LTD.**

408 Victoria Road, Gladesville, NSW 2111, Australia  
Phone: 02-9817-4666 Fax: 02-9817-4654

**TOPCON INSTRUMENTS (THAILAND) CO., LTD.**

77/162 Sinn Sathorn Tower, 37th Fl., Krungthongburi Rd., Klonglonsai, Klongsarn, Bangkok 10600 Thailand.

Phone: 662-440-1152-7 Fax: 662-440-1158

**TOPCON INSTRUMENTS (MALAYSIA) SDN. BHD.**

Lot 226 Jalan Negara 2, Pusat Bandar Taman Melawati, Taman Melawati, 53100, Kuala Lumpur, Malaysia.  
Phone: 603-41079801-2 Fax: 603-4107976

**TOPCON KOREA CORPORATION**

Hyobong Bldg., 1-1306, Seocho-Dong, Seocho-Gu, Seoul, Korea.  
Phone: 02-3482-9231 Fax: 02-3481-1928

**TOPCON OPTICAL (H.K.) LIMITED**

2/F, Meeco Industrial Bldg., No. 53-55 Au Pui Wan Street, Fo Tan Road, Shatin, N.T., Hong Kong  
Phone: 2690-1328 Fax: 2690-2221 E-mail: [sales@topcon.com.hk](mailto:sales@topcon.com.hk)

**TOPCON CORPORATION BEIJING OFFICE**

Room No.962 Poly Plaza Building, 14 Dongzhimen Nandajie, Dongcheng District, Beijing, 100027, China  
Phone: 10-6501-4191-2 Fax: 10-6501-4190

**TOPCON CORPORATION BEIRUT OFFICE**

P. O. BOX 70-1002 Antelias, BEIRUT-LEBANON.  
Phone: 961-4-523525/961-4-523526 Fax: 961-4-521119

**TOPCON CORPORATION DUBAI OFFICE**

Office No. 102, Khalaf Rashd Al Nayli Bldg., 245 Abu Hail Road, Deira, Dubai, UAE  
Phone: 971-4-696511 Fax: 971-4-695272

---

**TOPCON CORPORATION**

75-1 Hasunuma-cho, Itabashi-ku, Tokyo, 174-8580 Japan

Phone: 3-3558-2520 Fax: 3-3960-4214 <http://www.topcon.co.jp>